

# Lemair

## User Instruction

### Refrigerator

**MODEL NO. RQ-115M**  
**RQ-115BK**

Content	
1.Important Safeguards	page 1~3
2.Name of Parts	page 4
3.Correctly Positoning	page 5~6
4.Cautions	page 7
5.Changing the reversible door	page 8
6.Changing the light bulb	page 9
7.Maintanance and Troubleshooting	page 10
8.Technical Specifications	page 11
9.Warranty Card	page 12~13



# 1. Important Safeguards

**When using electrical appliances, in order to reduce the risk of fire, electric shock and/or injury, these basic safety precautions should always be followed:**

## 1. Important Safeguards

When using electrical appliances, basic safety precautions should always be followed, including the following:

- Carefully read this instruction manual before using appliance.
- Keep appliance out of reach of young children.
- This appliance is not intended for use by persons (including children) with reduced physical, sensory or mental capabilities, or lack of experience and knowledge, unless they have been given supervision or instruction concerning use of the appliance by a person responsible for their safety.
- Children should be supervised to ensure that they do not play with the appliance.
- Ensure children and babies do not play with plastic bags or any packaging materials.
- This appliance is heavy. Care should be taken when moving it. Do not pull or push using the door. Turn off and unplug before moving.
- Do not attempt to modify this product in any way.
- Whenever possible, the back of the appliance should be close to a wall but leaving the required distance for ventilation as stated in these instructions.
- Do not plug into the power socket before set up is completed. The appliance should be left to stand for 2 hours after installation and before turning on to allow the refrigerant to settle.
- **VERY IMPORTANT:**
  - Ensure that appliance does not get wet (water splashes etc.).
  - Do not use appliance with wet hands.
  - Do not immerse appliance in water or other liquids or use near sinks, baths or showers.
- Always operate the appliance from a power source of the same voltage, frequency and rating as indicated on the product identification plate.
- Position the power supply lead properly so that it will not be walked on, pinched by items placed on or against it or have the appliance resting on it.
- This appliance is intended to be used in household and similar applications such as:
  - staff kitchen areas in shops, offices and other working environments
  - farm houses and by clients in hotels, motels and other residential type environments
  - bed and breakfast type environments
  - catering and similar non-retail applications

# 1. Important Safeguards

**WARNING:** Keep ventilation openings, in the appliance enclosure or in the built-in structure, clear of obstruction.

**WARNING:** Do not use mechanical devices or other means to accelerate the defrosting process, other than those recommended by the manufacturer.

**WARNING:** Do not damage the refrigerant circuit.

**WARNING:** Do not use electrical appliances inside the food storage compartments of the appliance, unless they are of the type recommended by the manufacturer.

- Do not use appliance if it has been dropped or any part of appliance (including cord or plug) has been damaged. Take appliance to your nearest authorised service centre or qualified dealer for inspection or repair.
- Use only accessories recommended or supplied by an authorised service centre or qualified dealer. The use of accessories not intended for use with this appliance may cause injuries to the user or damage to the appliance.
- Do not install the unit on other appliances, on uneven surfaces or where it could be subject to: heat sources (e.g. radiators or stoves), direct sunlight, excessive dust or mechanical vibrations.
- Appliance should not be used outdoors, placed near a hot gas or electrical burner or placed in a heated oven.
- Do not install near any heat sources such as radiators, heat registers, stoves, or other apparatus that produce heat.
- Do not operate appliance underneath or near flammable or combustible materials (e.g. curtains).
- Unplug this appliance before cleaning or storing or when unused for long periods of time.
- Any type of servicing, apart from ordinary cleaning, must be carried out by an authorised service centre or qualified dealer. There are no user serviceable parts in this appliance.
- If this appliance is used by a third party, please supply the instruction manual with it.
- Do not misuse the cord. Never carry the appliance by the cord or pull to disconnect it from the outlet. Instead, grasp the plug and pull to disconnect.
- To fix stably, the appliance must be placed on a flat and solid surface. It should not be laid on any soft material.
- When positioned or if moving the appliance ensure that it is not set horizontally or declined more than 45° or turned upside down.
- Do not use the unit in very hot or humid places, such as bathrooms or under direct sunlight.
- Close the appliance door immediately after putting in items so the inside temperature will not rise dramatically.
- It is not recommended to use this appliance with an extension cord or power board.
- Do not place any other appliance on top of the appliance.

# 1. Important Safeguards

- This appliance is designed for domestic use only, specifically for the storage of edible foodstuffs only.
- This product has not been designed for any uses other than those specified in this instruction Manual.
- An empty fridge can be a dangerous attraction to children. If disposing of the fridge, remove gaskets, latches, lids or the entire door from your unused appliance, or take other action to ensure the fridge is harmless.\

Contact your local council for proper instruction for disposing of the unused appliance.

- Do not store explosive substances such as aerosol cans with a flammable propellant in this appliance.



The Refrigerant Gas used in this appliance is flammable.

- No liability can be accepted for any damage caused by non-compliance with these instructions or any other improper use or mishandling of appliance.
- This product has not been designed for any uses other than those specified in this booklet

## Read and Save These Instructions

## 2. Name of Parts

### PARTS AND FEATURES

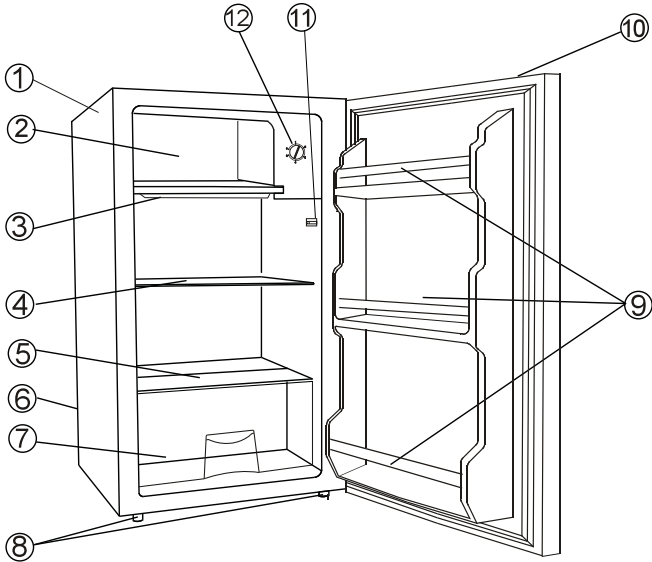

- ① Cabinet
- ② Cool zone compartment
- ③ Drip Tray
- ④ Shelf
- ⑤ Glass cover
- ⑥ Compressor(back)
- ⑦ Crisper box
- ⑧ Leveling Legs
- ⑨ Door Bar
- ⑩ Recessed Handle
- ⑪ Door switch
- ⑫ Temperature Control Knob

### 3. Correctly Positoning

#### Well Ventilating

There is need of good ventilation around the refrigerator for easy dissipation of heat, high efficiency of refrigeration and low power consumption. For this purpose, sufficient clear space should be need around the refrigerator. Its back is at least 100mm away from the wall, its sides at least have a space of 100mm separately and the height from over its top is not less than 200mm. A clear space should be left to open its doors to 160°

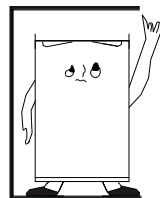

#### Power Supply

The refrigerator is only applied with power supply of single phase alternating current of (220-240)V~50Hz. If fluctuation of voltage in the district user is so large that the voltage exceeds the above scope, for safety sake, be sure to apply a.c. automatic voltage regulator to the refrigerator. The refrigerator must employ a special power socket instead of common one with other electric appliances. Its plug must match the socket with ground wire.

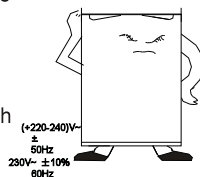

#### Power Line Cord

The cord should be neither lengthened nor folded into coil during operation. Moreover, it is forbidden that cord is kept close onto the compressor at the back of the refrigerator, the surface temperature of which is quite high when operating. Touching with it would deactivate the insulation or cause leakage for electricity.

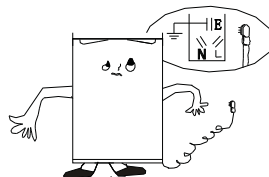

#### Protection from Moisture

Avoiding placing the refrigerator in a place where heavy moisture is present so as to minimize possibility of rusty for its metal parts. Still more, the refrigerator is forbidden to be directly sprayed by water, otherwise, poor insulation and current leakage would occur.



### 3. Correctly Positoning

#### Protection from Heat

The refrigerator should be far away from any heat source or direct sunshine.



#### Fixing Stable

Floor on which refrigerator will be placed must be flat and solid. It should not be laid on any soft material such as foam plastic, etc. If the refrigerator is not on the same level, adjust the screws suitably. The refrigerator should not be placed near anything which may echo.

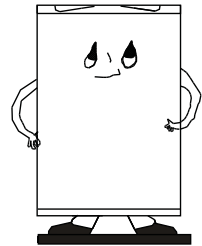

#### Keep Away from Danger

It is inadvisable that the refrigerator is placed near any volatilizable or combustible such as gas, petrol, alcohol, lacquer and banana oil, etc. The above-mentioned objects can not be stored in the refrigerator.

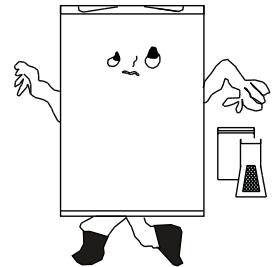

#### Moving

When fixed or moved, the refrigerator can not be set horizontally or declined to more than 45° or upside-down.

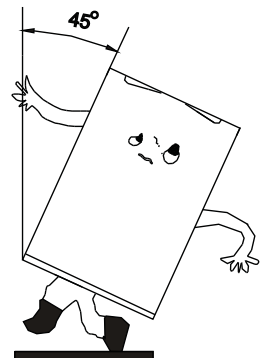



## 4. Cautions

- ★ Water contained in food or getting into air inside the refrigerator by opening doors may form a layer of frost inside. It will weaken the refrigerator when the frost is thick, while it is more than 2mm thick, you should defrost.
- ★ Defrosting in freezer chamber is operated manually. Before defrosting, take the food, the ice tray and the shelf out into the cold storing chamber temporarily then set the knob of the temperature regulator to position "0" (where the compressor will stop working) and leave the door open until ice and frost dissolve thoroughly deposited at the bottom of the freezer chamber, wipe off the water with soft cloth. In the case of speeding up the defrosting, you may put a bowl of warm water (about 50°C) into the freezer chamber, and be sure to set the knob of the temperature regulator to original position after defrosting.
- ★ It's inadvisable to heat the freezer chamber directly with hot water or hair dryer while defrosting to prevent deformation of the inner case.
- ★ It's also inadvisable to scrape of ice and frost or separate food from the containers which have been congealed together with the food with sharp tool or wooden bars, so as not to damage the inner casing or the surface of the evaporator.
- ★ If the supply cord of this appliance is damaged, it must only be replaced by a repair shop appointed by the manufacturer, because special purpose tools are required.
- ★ This appliance is not intended for use by person (including children) with reduced physical, sensory or mental capabilities, or lack of experience and knowledge, unless they have been given supervision or instruction concerning use of the appliance by a person responsible for their safety.
- ★ Children should be supervised to ensure that they do not play with the appliance.
- ★ Cool zone compartment is more suitable for food storage with lower temperature ( $0^{\circ}\text{C} \leq t \leq 6^{\circ}\text{C}$ ).

## 5. Changing the reversible door

This refrigerator has been built with the door hinges on the right. If you wish to change the opening direction, follow the instructions below:

1. Remove the upper hinge cover(6) first.
2. Remove the two screws (1) that hold the upper hinge (5) (right side) to the frame. Take away the upper hinge (5).
3. Lift the door and place it on a padded surface to prevent scratching it.
4. Remove the two screws(8) that hold the lower hinge(2) and Make sure to Remove the lower hinge(2).
5. Remove the left front leg (4) and transfer it to the right side.
6. Remove the hole cover plate(7) to the right side.
7. Before placing this lower hinge(2), remove the bolt-pin (9) and reverse the direction of the lower hinge(2). Then install the lower hinge (2) onto the left side of the lower frame with two screws (8).
8. Insert the bolt-pin(9) to the lower hinge (2).
9. Set the door to its place making sure the door seat at the lower hinge(2).
10. While holding the door in the closed position secure the upper hinge (5) in the top frame of left side with two screws (1). Please remember that do not tighten the two screws(1) until the top of the door is levelled with the counter top.
11. Install the upper hinge cover(6) on the upper hinge.

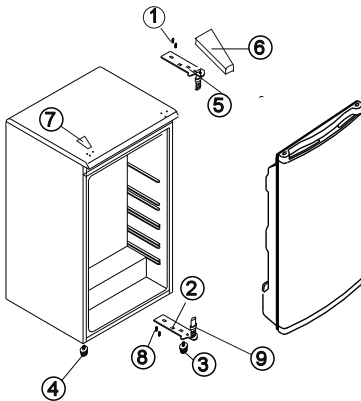

**FIGURE 1**

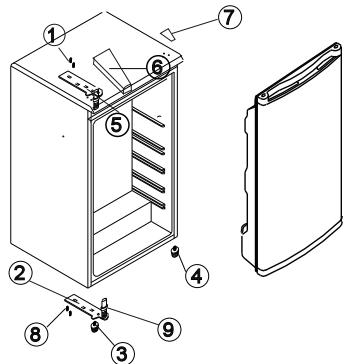

**FIGURE 2**

FIGURE 1 - REPRESENTS POSITION OF COMPONENTS PRIOR TO DOOR REVERSAL.

FIGURE 2 - REPRESENTS POSITION OF COMPONENTS AFTER DOOR REVERSAL.

## 6. Changing the light bulb

### Replacing bulbs:

When replacing the bulb, unplug the appliance from the mains, proceed as follows:

1. Remove the water drip tray.
2. Hold the lamp cover and push toward inside of the cabinet.
3. Remove the lamp cover.
4. Unscrew the bulb and screw in a new 10W bulb.
5. Hold the lamp cover and put the hook of the lamp cover to click into the thermostat box.
6. Pull the lamp cover forward to click into the thermostat box.
7. Replace the drip tray.

Thermostat

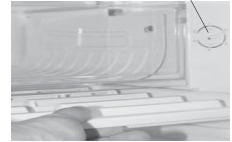

Lamp cover

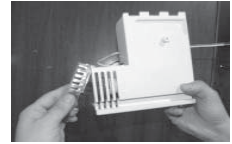
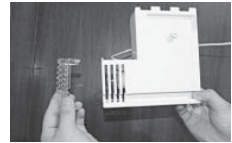
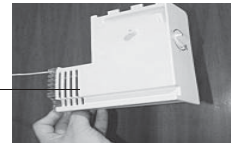

## 7. Maintenance and Troubleshooting

### Maintenance

#### Clean the outside using a soft cloth.

#### Prolonged disuse

1. Empty the refrigerator.
  2. Disconnect the appliance from the power supply.
  3. Defrost and clean the interior.
  4. In the event of prolonged disuse, leave the door open to prevent the formation of mould, odours and oxidation.
  5. Clean the appliance.
    - . Clean the inside of the low temperature compartment (where fitted) when defrosting.
    - . Periodically clean the inside of the refrigerator compartment with a sponge dampened in warm water and/or neutral detergent. Rinse and dry with a soft cloth.
- Do not use abrasive products. Do not use abrasive products, scourers, stain-removers e.g. acetone, trichloroethylene) or vinegar.

### Troubleshooting

1. When the refrigerator does not work
  - Check if there is a power failure.
  - Check if the power plug is plugged into the power outlet.
  - Check that the fuse has not blown.
2. When the refrigerator is cooling excessively
  - The temperature control dial may be set too high.
  - If you place foodstuffs containing a lot of moisture directly under the cool air outlets, they will freeze easily. This does not indicate a malfunction.
3. When the refrigerator is not cooling sufficiently
  - The food may be packed too tightly together which will block the flow of cool air.
  - You may have put something hot or a lot of foodstuffs into the refrigerator .
  - The door may not have been closed properly.
  - The door gaskets may be damaged.
  - The refrigerator may not be ventilated.
  - There may be insufficient clearance between the refrigerator and the surfaces immediately both sides and above.
  - The temperature control dial may not be set properly.
4. When the defrosting water overflows inside the refrigerator and onto the floor.
  - Check that the drain pipe and the drain hose are not clogged.
  - Check that the drain pan is housed properly.

5. When condensation form on the outside of the refrigerator.

Condensation may form on the outside when the humidity is high such as during a wet season. This is the same result as the condensation formed when chilled water is poured into a glass. It does not, therefore, indicate a failure, wipe dry with a dry cloth.

6. When you hear a sound like water flowing .

A sound like water flowing is the refrigerant flowing. It does not Indicate a malfunction.

7. When the cabinet's side panel heats up

The side panel of the cabinet will heat up when the door is opened or closed frequently, when starting the unit and when the unit operates in summer with high ambient outside temperature, In such case, do not touch the panel, it results from the dissipation of the heat from inside the cabinet, and it does not mean that something is wrong with the refrigerator.

## 8. Technical Specifications

\*For the detailed technical specifications, please refer to the nameplate at the back of the refrigerator.

\*Specifications are subject to change without prior notice.

### R600a Refrigerant Warning

- This appliance contains a small quantity of R600a refrigerant which is environmentally friendly, but flammable. It does not damage the ozone layer, nor does it increase the greenhouse effect.
- During transportation and installation, ensure that the tubing of the refrigerant circuit is not damaged.
- Leaking refrigerant can ignite and may damage the eyes.
- In the event any damage does occur, avoid exposure to open fires and any device which creates a spark. Disconnect the appliance from the mainspower.
- Thoroughly ventilate the room in which the appliance is located for several minutes.
- The room for installing the appliance must be at least 1 cubic metre per 8 grams of refrigerant. The refrigerant quantity contained in this appliance is noted on the Rating Plate of the appliance.



[www.hapl.com.au](http://www.hapl.com.au)

# HOME APPLIANCES

Congratulations on your new purchase and thank you for choosing a brand supported by Home Appliances Pty Ltd.



Our friendly Customer Care team will take care of your every enquiry.  
Please ring 1800 444 357 or email [customer care@hapl.com.au](mailto:customer care@hapl.com.au)

Please be aware of the terms and conditions following.

# FOR AUSTRALIA ONLY

## WARRANTY TERMS & CONDITIONS

**This warranty is in addition to your normal statutory entitlements and specific legal rights. Our goods come with guarantees that cannot be excluded under the Australian Consumer Law as prescribed and set out in regulation 90 of the Competition and Consumer Act 2010.**

1 Home Appliances Pty Limited warrants this appliance to the original purchaser against defective materials and workmanship for a period of **24 months** of ownership, that any part with defective material be replaced free of charge, provided that all service work is carried out by Home Appliances Pty Limited or nearest appointed service agent.

**3 months warranty (Non Domestic USE)**

Regardless of the product type, warranty of appliances installed and operated in a non domestic installation, such as an office or factory etc., is limited to Three (3) Months from date of purchase.

**NOTE:** Portable Appliances such as Benchtop cook tops are **NOT** covered for In House servicing, call Customer Care on **1800 444 357** to discuss servicing of this type of appliance.

2 If you are located **25 kilometres** outside a recognised Home Appliances Pty Limited service area the purchaser must cover the cost of sending the appliance to the service centre or any extra travel cost incurred by the technician in order to service the appliance.

3 If there is a defect in the materials or workmanship during the period of this warranty, Home Appliances Pty Limited will, at its discretion and subject to the following terms and conditions, repair or replace free of charge the component or appliance. Replacement of the appliance under the terms of this warranty does not give right to extension or a new beginning of the period of warranty.

4 Home Appliances Pty Limited is not liable for any other loss other than the appliance itself.

5 This warranty does not cover the following circumstances:

- (i) An act or acts of God, any natural occurrence or other circumstances not within the control of Home Appliances Pty Limited (such as fire, storm or water damage).
- (ii) An attempt by any person (other than an employee or authorised service agent of Home Appliances Pty Limited to repair or modify the appliance.
- (iii) Where the rating plate has been removed or any details on that plate have been rendered illegible.
- (iv)\*If the appliances have been installed, operated or maintained in a manner that is not in accordance with the instructions supplied by Home Appliances Pty Limited.

- (v) If product failure is the result of connection to a power supply that does not correspond to that shown on the ratings plate or if the power supply is inadequate or faulty.
- (vi) Normal wear and tear, misuse or damage to the appliance or use of the appliance in a manner for which it was not intended.

(vii) Failure of electrical components due to power surges or outages.

(viii) Home Appliances Pty Limited will not be obliged to comply with its obligations under this Warranty until you have paid the full purchase price for the appliances.

\* For Washing machines this includes removal of packaging material and rear packing bolts where applicable.

6 The warranty does not extend to cover:

- (i) Discoloured burners or trivets on gas cooktops or chrome surrounds on electric cooktops
- (ii) Discolouration caused by steam, heat or venting during normal use
- (iii) Plastic or enamel components
- (iv) Light globes, filters or any consumables
- (v) Insect or vermin infestation
- (vi) Corrosion where the product is located within a corrosive environment

7 Home Appliances Pty Limited excludes all warranties and conditions that may be implied into this Warranty or the Contract for Supply and limits its liability for a breach of any implied condition or warranty that cannot be excluded to the greater of (at Home Appliances Pty Limited option):

- (i) For goods, repairing or replacing those goods or paying for the cost of those goods repaired or replaced; and
- (ii) For services, resupplying the services or paying for the cost of having those services resupplied.

8 Proof of purchase will be required for the validation of all warranty claims.

9 Our goods come with guarantees that cannot be excluded under the Australian Consumer Law. You are entitled to a replacement or refund for a major failure and for compensation for any reasonably foreseeable loss or damage. You are also entitled to have the goods repaired if the goods fail to be of acceptable quality and the failure does not amount to a major failure.

**Built-In & Freestanding Appliances**

Access must be granted within normal working hours and our Service Agents must have easy access to these appliances. Any charges will be the responsibility of the purchaser where the service technician cannot obtain easy access to remove the appliances for inspection prior to repair.

## PROOF OF PURCHASE

Proof of purchase will be required for the validation of all warranty claims. Documents suitable for proof of purchase include, but are not limited to the following:

- Delivery dockets;
- Retailer or supplier invoices;
- Kitchen cabinet invoices that incorporate appliances;
- Credit card statements where the purchase of the appliances are clearly depicted.

The inability to provide proof of purchase will lead to the claim being treated as a service call with labour and parts costs being born by the claimant. It is recommended to attach any supporting documentation to this warranty card and keep in a safe place for future reference.

**NOTE:** There is no need to return this or any other warranty card to Home Appliances Pty Limited.

Proof of purchase is the only requirement for warranty claim, please keep a copy of the purchase receipt with this warranty card.